

I/A Series®

MicroNet™ VAV Series Controllers

The I/A Series MicroNet VAV (Variable Air Volume) Controllers are interoperable controllers designed in accordance with LONMARK® guidelines. When programmed using WorkPlace Tech Tool or loaded with a pre-engineered application, they provide a wide range of control strategies for pressure independent terminal boxes with, or without, reheat capabilities. Both models provide an integral actuator with manual override, an integral patented pressure transducer, one digital input, one universal input, Sensor Link (S-Link) support, LED indication, and over-the-shaft damper mounting. In addition, the MNL-V2RVx model provides one analog output and three digital outputs. These controllers can function either in a standalone mode or as part of a LONWORKS® FTT-10 Free Topology communications network.

Applications

Designed for new or existing systems, the VAV series controllers may be applied to pressure independent terminal boxes with, or without, reheat capabilities. The VAV series controllers offer the following types of Box Configuration and Reheat control strategies:

- Cooling
- Staged Electric Reheat
- Series Fan
- Floating/Proportional Hydronic Reheat
- Parallel Fan
- Time Proportioned
- Induction

Connectivity

The VAV series controllers offer the advantages of standalone or networked control. Using an I/A Series MicroNet Sensor (MN-Sx series), the operator can monitor controller performance and edit operational values. The WorkPlace Tech Tool software is used to program the controllers or download applications from the application library.

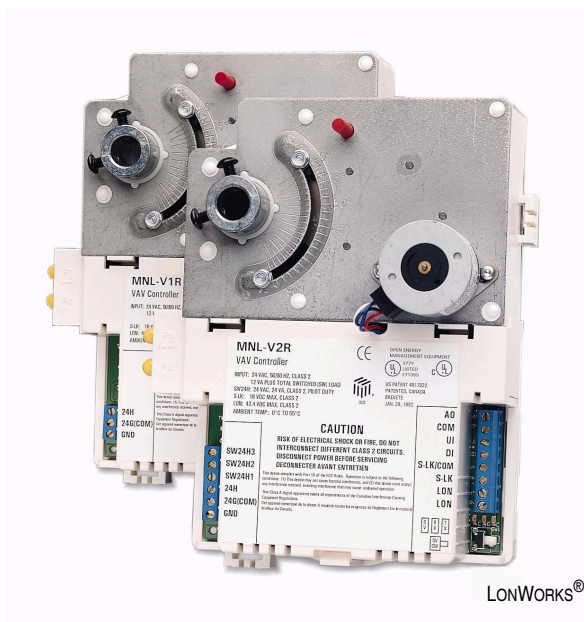

Features —

- Capability to function in standalone mode or as part of a LONWORKS FTT-10 Free Topology communications network.
- Integrated packaging with actuator, pressure transducer, and controller.
- Patented pressure transducer for years of reliable, accurate air flow readings.
- Integral actuator with manual override and travel limit settings for easy set up and support.
- Proportional (P), Proportional Plus Integral (PI), and Proportional Plus Integral and Derivative (PID) control for cooling and heating.
- Both controller models have plenum-rated enclosures.
- Air balancing using the I/A Series MicroNet VAV Flow Balance software.
- Conforms to the LONMARK VAV controller profile.

Invensys®

Invensys Building Systems, Inc.
1354 Clifford Avenue
P.O. Box 2940
Loves Park, IL 61132-2940
www.invensysibs.com

Model Chart

Model	Inputs/Outputs				Control Strategies		
	Digital Inputs	Digital Outputs	Universal Inputs	Analog Outputs	Box Configuration	Reheat Type	Other
MNL-V1RVx ^a	1	0	1	0	• Cooling	• None	• None
MNL-V2RVx ^a	1	3	1	1	• Cooling • Series Fan • Induction • Parallel Fan	• Staged Electric Reheat • Floating/Proportional Hydronic Reheat • Time Proportioned	• Occupancy • Satellite ^b

^a V denotes LONMARK VAV (Variable Air Volume) profile. "x" denotes profile version.

^b Available control strategies depend on controller I/O.

Hardware Specifications

Dimensions 7 3/4" high x 6 1/4" wide x 2 1/2" deep
(197 mm x 159 mm x 63 mm).

Enclosure Conforms to NEMA-1 requirements.
Meets UL94-5V flammability for plenum application use.

Conduit Knockouts Not applicable. Order optional MicroNet Enclosure, MNA-FLO-1, if wiring to flexible conduit is desired.

Power Supply Input 20.4 to 30 Vac, 50/60 Hz.

Maximum Power Consumption

MNL-V1RVx Maximum 12 VA.

MNL-V2RVx Maximum 84 VA (12 VA plus DO loads @ 24 VA each).

Surge Immunity Compliance

ANSI C62.41 (IEEE-587, Category A & B).

Agency Listings

FCC Class B.

UL

UL-916 (File # E71385 Category PAZX).

UL Listed to Canadian Safety Standards (CAN/CSA C22.2).

European Community – EMC Directive 89/336/EEC
EN61326

Ambient Limits

Operating Temperature 32 to 131 °F (0 to 55 °C).

Shipping and Storage Temperature -40 to 160 °F
(-40 to 71 °C).

Humidity 5 to 85% RH, non-condensing.

Wiring Terminals Screw terminals. Single AWG #14 (2.08 mm²) wire. Up to two AWG #18 (0.823 mm²) or smaller wires.

Velocity Pressure Input

Operating Range 0.0 to 2.5 in. of W.C. (0.0 to 0.622 kPa).

Control Range 0.01 to 2.00 in. of W.C. (0.0025 to 0.498 kPa).

Accuracy ± 5% @ 1.00 in. of W.C. (0.249 kPa) with Laminar flow @ 77 °F (25 °C) and suitable flow station.

Sensor Type Self-calibrating flow sensor (differential pressure).

Tubing Connections Barb fittings for 0.170" I.D. FRPE polyethylene tubing or 1/4" O.D./0.125" I.D. tygon tubing (high and low pressure taps).

Tubing Length 5 ft. (1.52 m) maximum each tube.

Inputs from MN-Sx I/A Series MicroNet Sensor.

Inputs	Description	MN-Sx Sensor
Space Temperature	32 to 122 °F (0 to 50 °C)	MN-S1, MN-S1HT, MN-S2, MN-S2HT, MN-S3, MN-S3HT, MN-S4, MN-S4HT, MN-S4-FCS, MN-S4HT-FCS, MN-S5 and MN-S5HT
Space Humidity	5 to 95% RH, Non-condensing	MN-S1HT, MN-S2HT, MN-S3HT, MN-S4HT, MN-S4HT-FCS, and MN-S5HT
Adjustable Setpoint	40 to 95 °F (4 to 35°C)	MN-S3, MN-S3HT, MN-S4, MN-S4HT, MN-S4-FCS, MN-S4HT-FCS, MN-S5, and MN-S5HT
Override Pushbutton	For standalone occupancy control or remote status monitoring of local status condition.	MN-S2, MN-S2HT, MN-S3, MN-S3HT, MN-S4, MN-S4HT, MN-S5, and MN-S5HT
Fan Operation and Speed	Fan mode selection: On, Speed (Low/Medium/High), or Auto.	MN-S4, MN-S4HT, MN-S4-FCS, MN-S4HT-FCS, MN-S5, and MN-S5HT
System Mode	System mode selection: Heat, Cool, Off, or Auto.	MN-S4, MN-S4HT, MN-S5, and MN-S5HT
Emergency Heat	Emergency heat mode selection: Enable or Disable	MN-S5 and MN-S5HT

Actuator Output

Torque Rating 53 lb-in. (6 N-m).

Stroke Fully adjustable from 0° to 90°.

Timing Approximately 3 minutes at 60 Hz (3.6 minutes at 50 Hz) for 90° rotation @ 24 Vac.

Position Indication Provides a visual indication of position.

Manual Override Pushbutton to allow manual positioning of the damper.

Damper Linkage 1/2" (12.75 mm) or 3/8" (9.5 mm) diameter round shaft extending 7/8" (22.23 mm) minimum from terminal box. 3/8" (9.5 mm) diameter shaft requires AM-135 adapter kit.

Digital (Relay) Outputs (MNL-V2RVx)

SW24H1, SW24H2, and SW24H3 Current Ratings 24 VA each at 24 Vac, 50/60 Hz. Form A Single Pole Single Throw (SPST). Normally open. 300K cycles at 24 Vac, 24 VA (0.4 power factor).

Digital Input Dry Contact. Detection of closed switch requires less than 300 Ω. Detection of open switch requires more than 100K Ω.

Universal Input

1K Ω Balco Input -40 to 250 °F (-40 to 121 °C) range. TSMN-81011, TS-8000 Series or equivalent.

1K Ω Platinum Input -40 to 240 °F (-40 to 116 °C) range. TSMN-58011, TS-5800 Series or equivalent.

1K Ω Resistance 0 to 1.5K Ω.

10K Ω Thermistor w/ 11K Ω Shunt Resistor -40 to 250 °F (-40 to 121 °C) range. TSMN-57011-850, TS-5700-850 Series or equivalent.

10K Ω Resistance 0 to 10.5K Ω.

Voltage 0 to 5 Vdc.

Current 0 to 20 mA requires an external 250 Ω shunt resistor.

Digital Input Dry Contact. Detection of closed switch requires less than 300 Ω resistance. Detection of open switch requires more than 1.5K Ω.

Analog Output (MNL-V2RVx)

Current 0 to 20 mA (output load from 80 to 550 Ω).

Software Capabilities

- Conforms to the LONMARK guidelines.
- WorkPlace Tech Tool is capable of reconfiguring and editing application configuration data to fit a wide range of variable air volume control requirements.
- HVAC interoperability achieved through use of LONMARK HVAC profiles.
- Air balancing provided by the I/A Series MicroNet VAV Flow Balance software.

I/A Series MicroNet VAV Flow Balance Software

Provides flow balancing for networked and standalone VAV series controllers. Features include:

- Local network control.
- Damper and fan adjustment.
- Setpoint monitoring and adjustment.
- Flow validation and calibration.
- Sequence, calibration, and control setpoint logs.

Communications

LONWORKS Networks A LONWORKS communications network uses an FTT-10 Free Topology configuration. Controllers on a LONWORKS network can communicate with each other in a peer-to-peer fashion. A LONWORKS network has a communications speed of 78k baud, using unshielded, twisted-pair cabling, with connections that are not polarity sensitive.

S-Link The Sensor Link (S-Link) communications wiring provides power and a communication interface for an MN-Sx I/A Series MicroNet sensor. The various MN-Sx sensors can provide room temperature, room humidity, setpoint adjustment, and occupancy override. This connection uses two-wire, unshielded cable and is not polarity sensitive. Maximum wire length allowed between a controller and an I/A Series MicroNet Sensor is 200 ft (61 m).

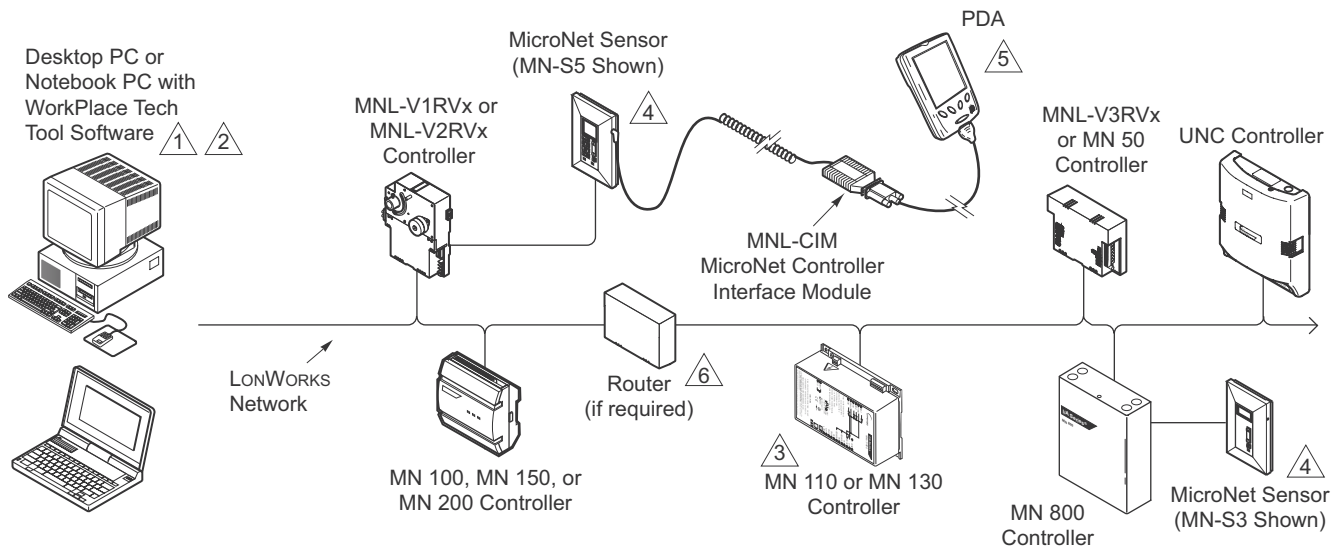

- 1 A PC can be connected to the LONWORKS TP/FT-10 Network, either directly or through the LONWORKS network jack of a LONWORKS controller or MN-Sxxx Wall Sensor. The PC must have an Echelon® LonTalk® adapter card.
- 2 Programming any of the I/A Series controllers, or the I/A Series MN 800 controller, requires WorkPlace Tech Tool.
- 3 This controller is not suitable for exposed mounting on a wall or panel, or in any other easily accessible place due to the possibility of personal contact with the high-voltage terminals. It must be mounted inside a suitable grounded metal enclosure.
- 4 MicroNet Sensors can be connected to any MN controller.
- 5 A PDA running the Pocket I/A interface software may be used to communicate with MicroNet I/A Series controllers.
- 6 When routers are used, WP Tech is able to communicate through them to any of the I/A Series devices on the network.

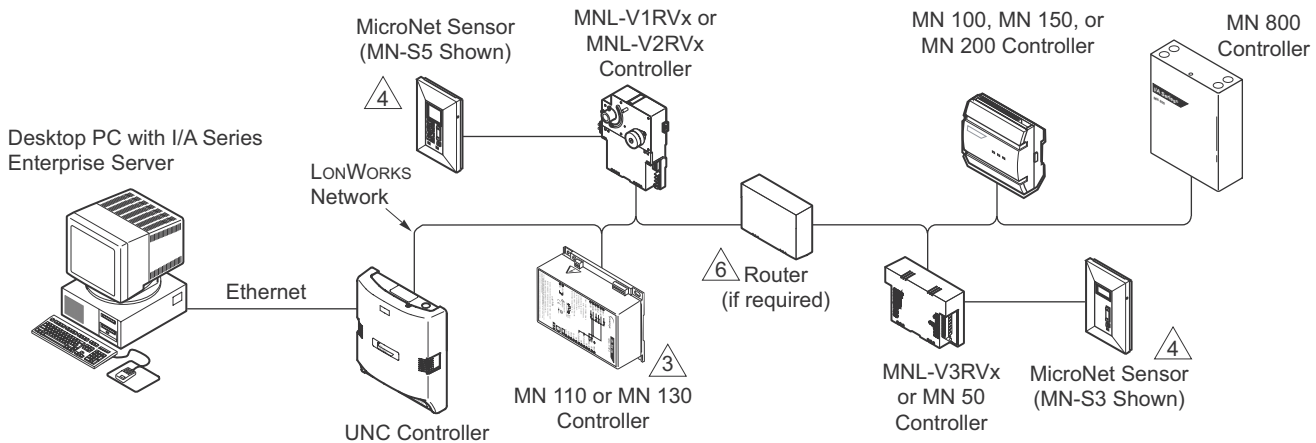

Figure-1 I/A Series MicroNet MN VAV Series Controller Connectivity.

© Copyright 2003 Invensys plc. All rights reserved.
 No part of this document may be photocopied or reproduced by any means, or translated to another language without prior written consent of Invensys.
 All specifications are nominal and may change as design improvements are introduced. Invensys shall not be liable for damages resulting from misapplication or misuse of its products.

I/A Series and MicroNet are trademarks of Invensys plc and its subsidiaries and affiliates.
 Echelon, LonTalk, LONMARK and LONWORKS are trademarks of Echelon Corporation registered in the United States and other countries.
 Microsoft and Windows are trademarks of Microsoft Corporation.