

**I/A Series®**

# MicroNet™ MN 110 and 130 Series Controllers

The I/A Series MicroNet 110 and 130 Controllers are programmable, interoperable controllers designed in accordance with LONMARK® guidelines. When programmed using WorkPlace Tech Tool (WP Tech), these controllers provide control for fan coil and unit ventilator applications. These controllers feature: screw terminal blocks; three universal inputs; three high-voltage relay outputs (only one for the MN 110); four 24 Vac Triac (digital) outputs; and an S-Link interface for connection to an optional MN-Sx I/A Series MicroNet Sensor.

The MN 110 and 130 controllers conform to the LONMARK Fan Coil Unit functional profile (8020), providing open communication and interoperability with third party LONMARK devices, and greater freedom in system design. These controllers can function in standalone mode or as part of a LONWORKS® TP/FT-10 Free Topology network.

## Applications

Especially suitable for new or existing system installations, the MN 110 and 130 controllers provide control for fan coil units and unit ventilators with direct connection(s) to one, two, or three electrical loads such as fans, pumps, relays, or electric heat, at up to 240 Vac at 3 A.

## Connectivity

MN 110 and 130 controllers offer the advantages of either standalone or network control. Support is also provided for an optional MN-Sx I/A Series MicroNet Sensor (see the table, "Inputs from MN-Sx I/A Series MicroNet Sensor," on page 3, for features).

The WorkPlace Tech Tool may be used to program the MN 110 and 130 controllers through the LONWORKS network jack on either the controller or a connected MN-Sx sensor.



## Features—

- One or three high-voltage relay outputs capable of directly powering typical 240 Vac, 3 A motors.
- Uses the LONMARK Fan Coil Profile 8020 for interoperability.
- Capability to function in standalone mode or as part of a LONWORKS TP/FT-10 Free Topology communications network.
- Onboard LED indication without cover removal.
- Compact size allows mounting in confined spaces.
- Four 24 Vac Triac outputs.
- Can be directly mounted on a wall, or on a DIN rail, within a suitable grounded metal enclosure.
- Built-in jack for connection to a LONWORKS network.

**Invensys®**

**Invensys Building Systems, Inc.**  
1354 Clifford Avenue  
P.O. Box 2940  
Loves Park, IL 61132-2940  
www.invensysibs.com

## Model Chart

Model	Description	Inputs/Outputs	Profiles
MNL-11RFx <sup>a</sup>	I/A Series MicroNet MN 110 Controller	3 Universal Inputs (UI)	• Fan Coil
		1 Line Voltage Relay Output (DO)	
		4 Triac Outputs (DO)	
MNL-13RFx <sup>a</sup>	I/A Series MicroNet MN 130 Controller	3 Universal Inputs (UI)	• Fan Coil
		3 Line Voltage Relay Outputs (DO)	
		4 Triac Outputs (DO)	

<sup>a</sup> x denotes LONMARK profile version .

## Hardware Specifications

**Dimensions** 4.2" high x 6.1" wide x 2" deep (107 mm x 154.9 mm x 50 mm).

**Enclosure** Molded ABS plastic case. Fire resistant to UL94VO.

**Power Supply Input** 24 Vac +25/-15%, 50/60 Hz.

### Maximum Power Consumption

**MNL-11RFx** 20.5 VA @ 24 Vac, 50/60 Hz (8.5 VA plus maximum DO1-DO4 total load of 0.5 A or 12 VA).

**MNL-13RFx** 21.5 VA @ 24 Vac, 50/60 Hz (9.5 VA plus maximum DO1-DO4 total load of 0.5 A or 12 VA).

### Surge Immunity Compliance

IEEE C62.41 (IEEE-587, Category A & B).

### Agency Listings

**FCC** Class B.

**UL**

UL-873 (File #E9429) Recognized Component.

UL Recognized Canadian Component.

**Australia** Meets requirements to bear the C-Tick Mark.

### European Community – EMC Directive 89/336/EEC

EN61326

### Low-Voltage Directive – 73/23/EEC

EN60730-1

**Mounting** Wall or 35 mm DIN rail, within a suitable grounded metal enclosure.



**Warning:** This controller is not suitable for exposed mounting on a wall or panel, or in any other easily accessible place due to the possibility of personal contact with the mains terminals. It must be mounted inside a suitable grounded metal enclosure.

### Ambient Limits

**Operating Temperature** -40 to 131 °F (-40 to 55 °C).

**Shipping and Storage Temperature** -40 to 160 °F (-40 to 71 °C).

**Humidity** 0 to 95% RH, non-condensing.

**Wiring Terminals** Screw terminal blocks. Low voltage screw terminals (all except high-voltage terminals) accept a single AWG #18 (0.823 mm<sup>2</sup>) or smaller wire. High-voltage screw terminals (DO5, C5, DO6, C6, DO7, and C7) accept a single AWG #14 (2.08 mm<sup>2</sup>) or smaller wire.

**Universal Inputs (3)** Universal Input characteristics are software-configured to respond to one of the following input types:

**10K Thermistor with 11K Shunt Resistor** Sensor operating range -40 to 250 °F (-40 to 121 °C), Invensys model TSMN-57011-850, TS-5700-850 series or equivalent.

**10K Resistance** 0 to 10.5K ohms.

**Balco** -40 to 250 °F (-40 to 121 °C), Invensys model TSMN-81011, TS-8000 series or equivalent.

**Platinum** -40 to 240 °F (-40 to 116 °C), Invensys model TSMN-58011, TS-5800 series or equivalent.

**1K Resistance** 0 to 1.5K ohms.

**Analog Voltage** Range 0 to 5 Vdc.

**Analog Current** Range 0 to 20 mA requires an external 250 Ω shunt resistor.

**Digital** Dry switched contact (N.O. or N.C.). Detection of closed switch requires less than 300 Ω. Detection of open switch requires more than 1.5 KΩ.

### Line Voltage Relay Outputs

**MNL-11RFx (1)** 3 A maximum at 240 Vac, cos φ = 0.4. Form A (SPST — normally open).

**MNL-13RFx (3)** 3 A maximum at 240 Vac, cos φ = 0.4. Form A (SPST — normally open).

**Triac Outputs (4)** Digital outputs for switching 24 Vac (0.5 A or 12 VA maximum total load for DO1-DO4 @ 24 Vac).

## Inputs from MN-Sx I/A Series MicroNet Sensor.

Inputs	Description	MN-Sx Sensor
Space Temperature	32 to 122 °F (0 to 50 °C)	MN-S1, MN-S1HT, MN-S2, MN-S2HT, MN-S3, MN-S3HT, MN-S4, MN-S4HT, MN-S4-FCS, MN-S4HT-FCS, MN-S5 and MN-S5HT
Space Humidity	5 to 95% RH, Non-condensing	MN-S1HT, MN-S2HT, MN-S3HT, MN-S4HT, MN-S4HT-FCS, and MN-S5HT
Adjustable Setpoint	40 to 95 °F (4 to 35°C)	MN-S3, MN-S3HT, MN-S4, MN-S4HT, MN-S4-FCS, MN-S4HT-FCS, MN-S5, and MN-S5HT
Override Pushbutton	For standalone occupancy control or remote status monitoring of local status condition.	MN-S2, MN-S2HT, MN-S3, MN-S3HT, MN-S4, MN-S4HT, MN-S5, and MN-S5HT
Fan Operation and Speed	Fan mode selection: On, Speed (Low/Medium/High), or Auto.	MN-S4, MN-S4HT, MN-S4-FCS, MN-S4HT-FCS, MN-S5, and MN-S5HT
System Mode	System mode selection: Heat, Cool, Off, or Auto.	MN-S4, MN-S4HT, MN-S5, and MN-S5HT
Emergency Heat	Emergency heat mode selection: Enable or Disable	MN-S5 and MN-S5HT

## Software Capabilities

- Allows design of a complete custom application for each controller.
- Conforms to the LONMARK guidelines.
- WorkPlace Tech Tool is capable of reconfiguring and editing application configuration data.
- Interoperability achieved through use of the LONMARK Fan Coil Profile 8020.

## Communications

**LONWORKS Networks** A LONWORKS communications network uses an TP/FT-10 Free Topology configuration. Controllers on a LONWORKS network can communicate with each other in a peer-to-peer fashion. A LONWORKS network has a communications speed of 78k baud, using unshielded, twisted-pair cabling, with connections that are not polarity sensitive.

**S-Link** The Sensor Link (S-Link) communications wiring provides power and a communication interface for an MN-Sx I/A Series MicroNet sensor. The various MN-Sx sensors can provide room temperature, room humidity, setpoint adjustment, and occupancy override. This connection uses two-wire, unshielded cable and is not polarity sensitive. Maximum wire length allowed between a controller and an I/A Series MicroNet Sensor is 200 ft (61 m).

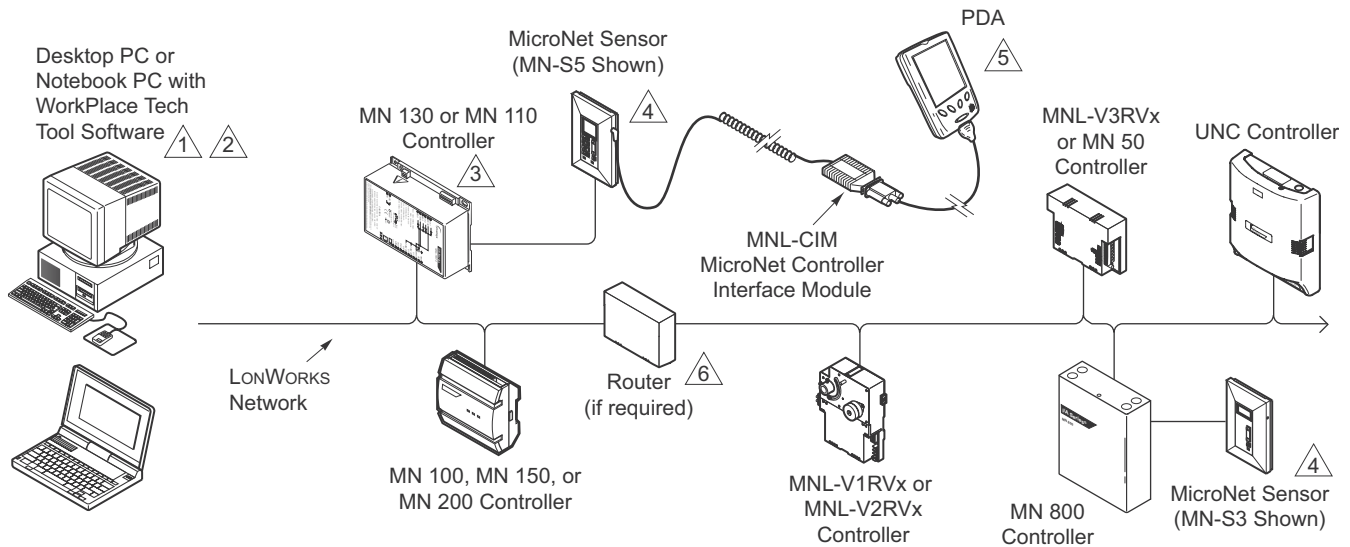

- 1 A PC can be connected to the LONWORKS TP/FT-10 Network, either directly or through the LONWORKS® network jack of a LONWORKS controller or MN-Sxxx Wall Sensor. The PC must have an Echelon® LonTalk® adapter card.
- 2 Programming any of the I/A Series controllers, or the I/A Series MN 800 controller, requires WorkPlace Tech Tool.
- ⚡ 3 This controller is not suitable for exposed mounting on a wall or panel, or in any other easily accessible place due to the possibility of personal contact with the high-voltage terminals. It must be mounted inside a suitable grounded metal enclosure.
- 4 MicroNet Sensors can be connected to any MN controller.
- 5 A PDA running the Pocket I/A interface software may be used to communicate with MicroNet I/A Series controllers.
- 6 When routers are used, WP Tech is able to communicate through them to any of the I/A Series devices on the network.

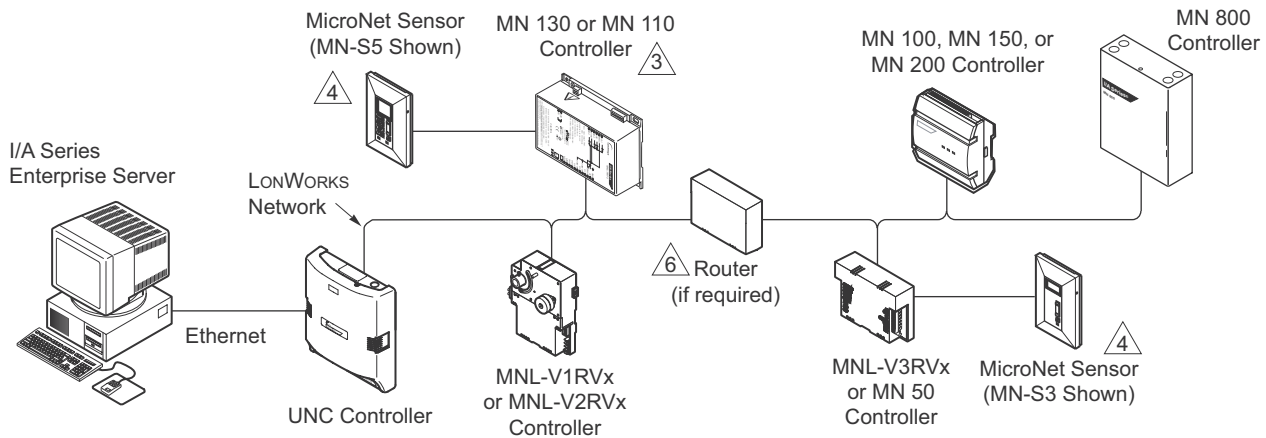

Figure-1 I/A Series MicroNet MN 110 and 130 Controller Connectivity.

© Copyright 2003 Invensys plc. All rights reserved.  
 No part of this document may be photocopied or reproduced by any means, or translated to another language without prior written consent of Invensys.  
 All specifications are nominal and may change as design improvements are introduced. Invensys shall not be liable for damages resulting from misapplication or misuse of its products.

I/A Series and MicroNet are trademarks of Invensys plc and its subsidiaries and affiliates.  
 Echelon, LonTalk, LONMARK and LONWORKS are trademarks of Echelon Corporation registered in the United States and other countries.  
 Microsoft and Windows are trademarks of Microsoft Corporation.