

I/A Series®

MicroNet™ 100, 150, and 200 Series Controllers

The I/A Series MicroNet 100, 150, and 200 Controllers are interoperable controllers designed in accordance with LONMARK® guidelines. When programmed using WorkPlace Tech Tool, or loaded with a pre-engineered application, these controllers provide control for packaged rooftops, heat pumps, fan coils, unit ventilators, and similar applications. Controllers feature Sensor Link (S-Link) support, LED indication, screw terminal blocks, as well as DIN rail or panel mounting ability. These controllers can function in either standalone mode or as part of a LONWORKS® TP/FT-10 Free Topology communications network.

The 100, 150, and 200 series controllers use the same physical packaging, but differ in the onboard I/O points they provide.



LONWORKS®

Applications

Designed for new or existing system installations, the MN 100, 150, and 200 controllers provide control for:

- Unit Ventilators
- Heat Pumps
- Fan Coils
- Packaged Rooftops

Connectivity

The MN series controllers offer the advantages of standalone and networked control. Using an I/A Series MicroNet Sensor (MN-Sx series), the operator can monitor controller performance and edit operational values. The WorkPlace Tech Tool software is used to program the controllers.

Features —

- Field programmable using WorkPlace Tech Tool.
- Uses LONMARK HVAC profiles for interoperability.
- Capability to function in standalone mode or as part of a LONWORKS TP/FT-10 Free Topology communications network.
- Multiple controllers on a LONWORKS FTT network creates a complex network of controllers for virtually any building control need.
- Proportional (P), Proportional Plus Integral (PI), and Proportional Plus Integral and Derivative (PID) control for cooling and heating.
- The satellite profile allows the controller to be used in a broad range of applications, providing solutions for your building control needs.
- Onboard LED indication without cover removal.
- Plenum-rated enclosure allows direct mounting in plenum.
- Protective hinged covers provide access to field wiring terminals.

invensys®

Invensys Building Systems, Inc.
1354 Clifford Avenue
P.O. Box 2940
Loves Park, IL 61132-2940
www.invensysibs.com

Model Chart

Model	Description	Inputs/Outputs	Profiles
MNL-10Rxx ^a	I/A Series MicroNet 100 Series Controller	1 Digital Input (DI)	<ul style="list-style-type: none"> • Heat Pump • Fan Coil • Packaged Rooftop • Satellite
		2 Universal Inputs (UI)	
		4 Digital Outputs (DO)	
MNL-15Rxx ^a	I/A Series MicroNet 150 Series Controller	3 Universal Inputs (UI)	<ul style="list-style-type: none"> • Heat Pump • Fan Coil • Packaged Rooftop • Satellite
		2 Digital Outputs (DO)	
		2 Analog Outputs (AO)	
MNL-20Rxx ^a	I/A Series MicroNet 200 Series Controller	2 Digital Inputs (DI)	<ul style="list-style-type: none"> • Heat Pump • Fan Coil • Packaged Rooftop • Satellite
		3 Universal Inputs (UI)	
		6 Digital Outputs (DO)	
		2 Analog Outputs (AO)	

^a xx denotes LONMARK profile and profile version (F=Fan Coil, H=Heat Pump, R=Rooftop, S=Satellite).
Satellite profile is based on Rooftop profile.

Hardware Specifications

Dimensions 4 5/16" high x 4 3/8" wide x 2" deep
(109 mm x 111 mm x 51 mm).

Enclosure Conforms to NEMA-1 requirements.
Meets UL94-5V flammability for plenum application use.

Conduit Knockouts Not applicable. Order optional MicroNet Enclosure, MNA-FLO-1, if wiring to flexible conduit is desired.

Power Supply Input 20.4 to 30 Vac, 50/60 Hz.

Maximum Power Consumption 15 VA @ 24 Vac, 50/60 Hz, excluding relay output power.

Surge Immunity Compliance IEEE C62.41 (IEEE-587, Category A & B).

Agency Listings

FCC Class B.

UL

UL-916 (File # E71385 Category PAZX).

UL Listed to Canadian Safety Standards (CAN/CSA C22.2).

European Community – EMC Directive 89/336/EEC

EN61326

Mounting 35 mm DIN rail or panel.

Ambient Limits

Operating Temperature -40 to 140 °F (-40 to 60 °C).

Shipping and Storage Temperature -40 to 160 °F (-40 to 71 °C).

Humidity 5 to 95% RH, non-condensing.

Wiring Terminals Screw terminals. Each terminal accepts one AWG #16 to #24 (1.31 to 0.205 mm² maximum) wire.

Inputs from MN-Sx I/A Series MicroNet Sensor.

Inputs	Description	MN-Sx Sensor
Space Temperature	32 to 122 °F (0 to 50 °C)	MN-S1, MN-S1HT, MN-S2, MN-S2HT, MN-S3, MN-S3HT, MN-S4, MN-S4HT, MN-S4-FCS, MN-S4HT-FCS, MN-S5 and MN-S5HT
Space Humidity	5 to 95% RH, Non-condensing	MN-S1HT, MN-S2HT, MN-S3HT, MN-S4HT, MN-S4HT-FCS, and MN-S5HT
Adjustable Setpoint	40 to 95 °F (4 to 35°C)	MN-S3, MN-S3HT, MN-S4, MN-S4HT, MN-S4-FCS, MN-S4HT-FCS, MN-S5, and MN-S5HT
Override Pushbutton	For standalone occupancy control or remote status monitoring of local status condition.	MN-S2, MN-S2HT, MN-S3, MN-S3HT, MN-S4, MN-S4HT, MN-S5, and MN-S5HT
Fan Operation and Speed	Fan mode selection: On, Speed (Low/Medium/High), or Auto.	MN-S4, MN-S4HT, MN-S4-FCS, MN-S4HT-FCS, MN-S5, and MN-S5HT
System Mode	System mode selection: Heat, Cool, Off, or Auto.	MN-S4, MN-S4HT, MN-S5, and MN-S5HT
Emergency Heat	Emergency heat mode selection: Enable or Disable	MN-S5 and MN-S5HT

Digital Inputs

(MN 100 and MN 200 only) Dry Contact. Detection of closed switch requires less than 300 Ω. Detection of open switch requires more than 100K Ω.

Digital Outputs

Current Ratings 24 VA at 24 Vac, pilot duty.

Universal Inputs

1KΩ Balco Input -40 to 250 °F (-40 to 121°C) range.

TSMN-81011, TS-8000 Series or equivalent.

1KΩ Platinum Input -40 to 240 °F (-40 to 116 °C) range.

TSMN-58011, TS-5800 Series or equivalent.

1k Resistance 0 to 1.5k ohms.

10KΩ Thermistor w/ 11KΩ Shunt Resistor -40 to 250 °F (-40 to 121 °C) range. TSMN-57011-850, TS-5700-850 Series or equivalent.

10k Resistance 0 to 10.5k ohms.

Voltage 0 to 5 Vdc.

Current 0 to 20 mA requires an external 250 Ω shunt resistor.

Digital Input Dry Contact. Detection of closed switch requires less than 300 Ω. Detection of open switch requires more than 1.5K Ω.

Analog Outputs (MN 150 and MN 200 only)

Current 0 to 20 mA. (Output load from 80 to 550Ω).

Software Capabilities

- Allows design of a complete custom application for each controller.
- Conforms to the LONMARK guidelines.
- WorkPlace Tech Tool is capable of reconfiguring and editing application configuration data.
- HVAC interoperability achieved through use of LONMARK HVAC profiles.
- All controllers are field programmable, but controllers with satellite profiles are especially suited for a broad range of applications, providing solutions for your building control needs.

Communications

LONWORKS Networks A LONWORKS communications network uses an TP/FT-10 Free Topology configuration. Controllers on a LONWORKS network can communicate with each other in a peer-to-peer fashion. A LONWORKS network has a communications speed of 78k baud, using unshielded, twisted-pair cabling, with connections that are not polarity sensitive.

S-Link The Sensor Link (S-Link) communications wiring provides power and a communication interface for an MN-Sx I/A Series MicroNet sensor. The various MN-Sx sensors can provide room temperature, room humidity, setpoint adjustment, and occupancy override. This connection uses two-wire, unshielded cable and is not polarity sensitive. Maximum wire length allowed between a controller and an I/A Series MicroNet Sensor is 200 ft (61 m).

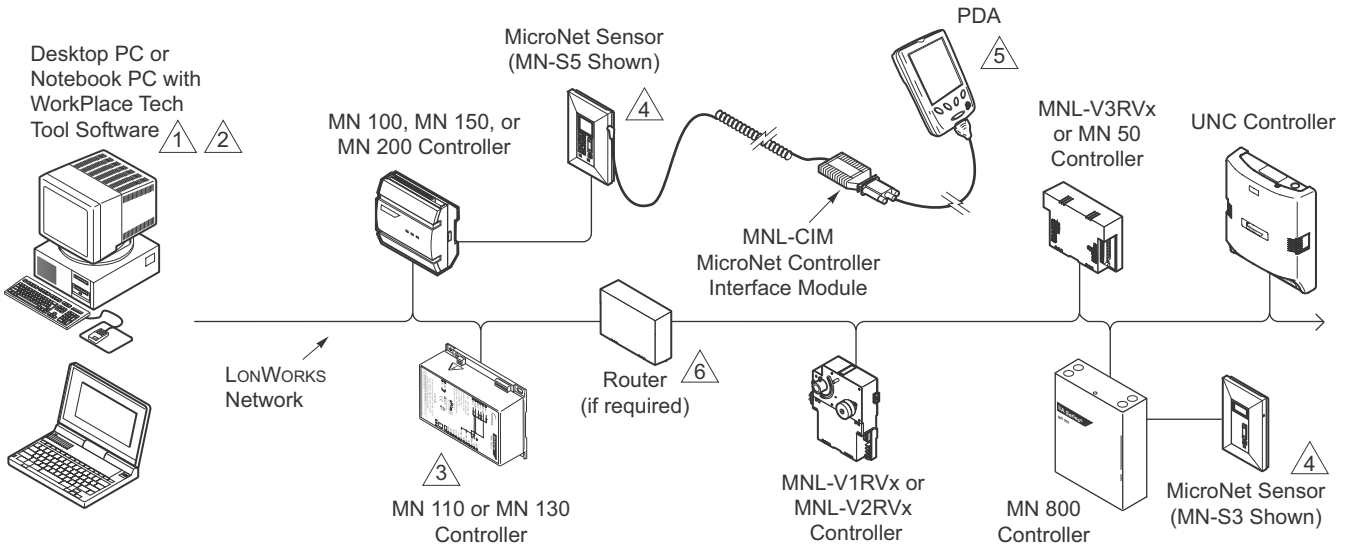

- 1 A PC can be connected to the LONWORKS TP/FT-10 Network, either directly or through the LONWORKS network jack of a LONWORKS controller or MN-Sxxx Wall Sensor. The PC must have an Echelon® LonTalk® adapter card.
- 2 Programming any of the I/A Series controllers, or the I/A Series MN 800 controller, requires WorkPlace Tech Tool.
- 3 This controller is not suitable for exposed mounting on a wall or panel, or in any other easily accessible place due to the possibility of personal contact with the high-voltage terminals. It must be mounted inside a suitable grounded metal enclosure.
- 4 MicroNet Sensors can be connected to any MN controller.
- 5 A PDA running the Pocket I/A interface software may be used to communicate with MicroNet I/A Series controllers.
- 6 When routers are used, WP Tech is able to communicate through them to any of the I/A Series devices on the network.

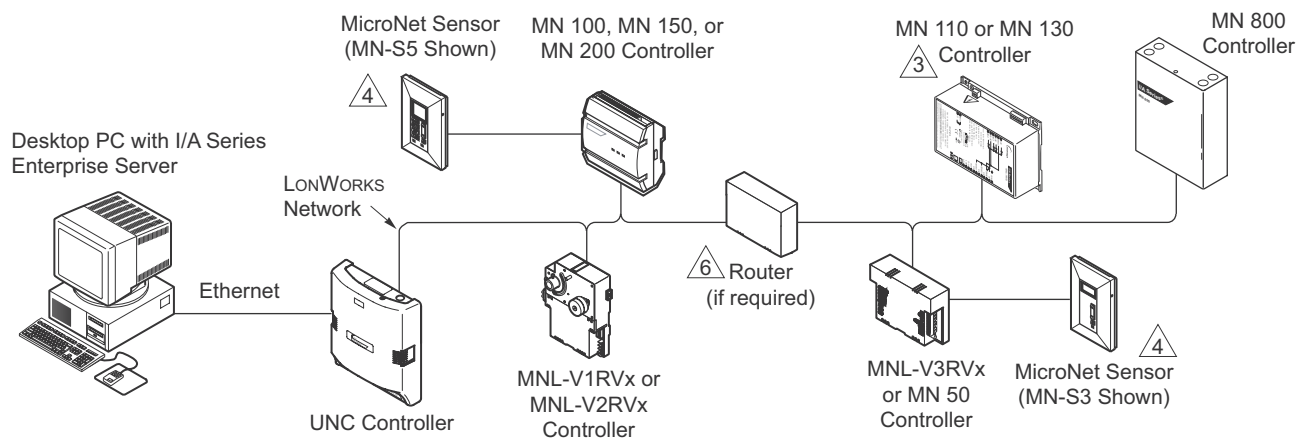

Figure-1 I/A Series MicroNet MN 100, 150, and 200 Series Controller Connectivity.

© Copyright 2003 Invensys plc. All rights reserved.
 No part of this document may be photocopied or reproduced by any means, or translated to another language without prior written consent of Invensys.
 All specifications are nominal and may change as design improvements are introduced. Invensys Building Systems shall not be liable for damages resulting from misapplication or misuse of its products.

I/A Series and MicroNet are trademarks of Invensys plc and its subsidiaries and affiliates.
 Echelon, LonTalk, LONMARK and LONWORKS are trademarks of Echelon Corporation registered in the United States and other countries.
 Microsoft and Windows are trademarks of Microsoft Corporation.