



TAC MicroNet BACnet Remote I/O Module

- Removable electronics module mates with panel-mounted subbase.
- Optional NEMA 1 enclosure.
- Removable terminals for power and communications, to facilitate commissioning.
- LED indication of compatibility, UO and DO (TO) state, and communication state (with the MNB-1000 controller).
- Fallback I/O function, in case of loss of communication between the Remote I/O Module and the MNB-1000 controller.
- DIP switch addressable (the MNB-1000 controller has a fixed address on the remote I/O network).
- Firmware upgraded automatically whenever the connected MNB-1000 controller's firmware is upgraded. Also, when a Remote I/O Module is physically connected to the MNB-1000 controller, its firmware is automatically upgraded if needed.

The TAC™ I/A Series™ MicroNet™ BACnet™ Remote I/O Module is designed to be an extension of the MNB-1000 Plant Controller, so as to expand the controller's I/O count.

When programmed using WorkPlace Tech Tool, each module increases the count by 15 inputs and outputs. Up to eight modules can be connected to a given MNB-1000 controller, for a potential increase of 120 I/O points, total. In this way, the controller's existing 32 onboard I/O can be expanded to 47 I/O points (with one module), up to a maximum total of 152 I/O points (with eight modules).

The Remote I/O Module features: LED indication of compatibility, communication status, and output indication; screw terminal blocks; a panel-mount sub-base with removable electronics module; a fallback I/O function; a DIP switch for addressing; and automated, over-the-network firmware upgrades.

Table-1 Model Chart.

Model	Description	Inputs and Outputs		
		UI	UO	DO (Triac)
MNB-1000-15	Remote I/O Module	6	3	6

Communications

Remote I/O

The remote I/O communications wiring provides an interface between the MNB-1000-15 Remote I/O Module and the MNB-1000 Plant Controller.

I/O Fallback Function

The Remote I/O Module's outputs are driven directly by the MNB-1000 Plant Controller, in which the application resides. If communications between the module and the controller is lost, the module's outputs are set to fallback values that were previously sent to the module during normal communications.

Options

MNB-BASE-15	Controller Base Assembly Only
MNB-CNTRLR-15	Controller Cover Assembly Only
MNB-300-ENC	Wall-mount Enclosure
TSMN Series	Room Temperature Sensors

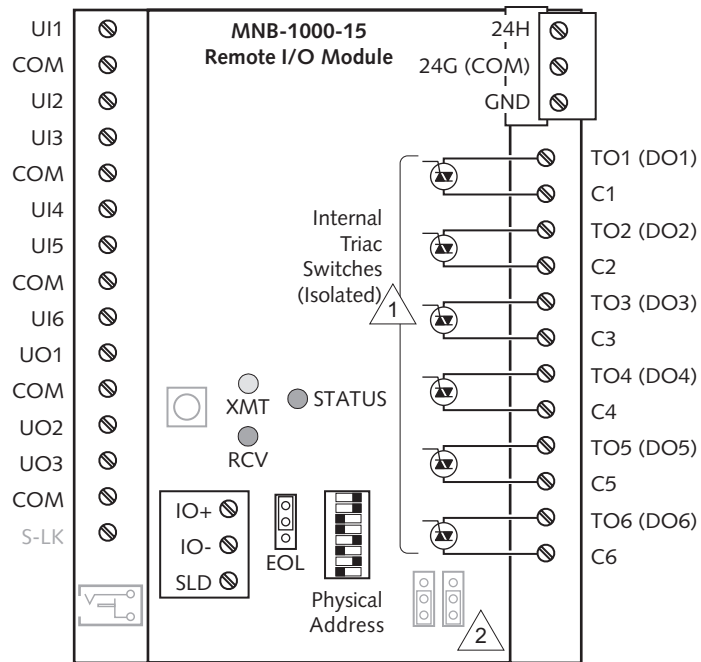

1 AC voltage for Triac switches must be supplied externally.

2 Bias for the remote I/O network is provided by the permanently enabled, built-in bias resistors on the MNB-1000 controller. The jumper-set bias resistors located under the cover of the Remote I/O Module are set to "Disabled" at the factory, and are not to be used for this purpose.

General Notes:

- Components are shown in their approximate locations.
- Features shown in gray, although present, are not used in the Remote I/O Module.

Figure-1 Remote I/O Module Terminals.

SPECIFICATIONS

HARDWARE SPECIFICATIONS

Dimensions

3-15/16 H x 7 W x 2-3/16 D in
(100 x 178 x 56 mm).

Enclosure

Optional enclosure conforms to NEMA-1. Meets UL 94-5V flammability ratings for plenum application use.

Mounting

Panel mount.

Power Supply Input

20.4 to 30 Vac, 50/60 Hz.

Power Consumption

16 VA at 24 Vac.

AGENCY LISTINGS

US

UL 916, File #E71385 Category PAZX
FCC Part 15, Class A.

Canadian

UL Listed to Canadian Safety Standards (CAN/CSA 22.2).

Australian

Meets requirements to bear the C-Tick Mark.

European Community

EMC Directive 89/336/EEC
EN61326

AMBIENT LIMITS

Operating Temperature

-40 to 140 °F (-40 to 60 °C).

Shipping and Storage Temperature

-40 to 160 °F (-40 to 71 °C).

Humidity

5 to 95% non-condensing.

WIRING TERMINALS (FIGURE-1)

I/O Points

Fixed screw terminals; single AWG #14 (2.08 mm²) wire or up to two AWG #18 (0.823 mm²) or smaller wires.

Remote I/O

Removable screw terminals; single AWG #14 (2.08 mm²) wire or up to two AWG #18 (0.823 mm²) or smaller wires.

Power

Removable screw terminals; up to two AWG #14 (2.08 mm²) or smaller wires.

UNIVERSAL INPUTS (6)

Universal Input characteristics are software-configured to respond to one of the following input types:

10k ohm Thermistor with 11k ohm Shunt Resistor

Sensor operating range -40 to 250 °F (-40 to 121 °C), TAC model TSMN-57011-850, TS-5700-850 series, or equivalent.

1k ohm Balco

-40 to 250 °F (-40 to 121 °C), TAC model TSMN-81011, TS-8000 series, or equivalent.

1k ohm Platinum

-40 to 240 °F (-40 to 116 °C), TAC model TSMN-58011, TS-5800 series, or equivalent.

1k ohm Resistive

0 to 1500 ohms.

10k ohm Resistive

0 to 10.5k ohms.

Analog Voltage

Range 0 to 5 Vdc.

Analog Current

Range 0 to 20 mA; requires external 250 ohm shunt resistor (AD-8969-202).

Digital

Dry switched contact; detection of closed switch requires less than 300 ohms resistance; detection of open switch requires more than 2.5k ohms.

Standard Pulse Input (UI1-UI6)

Minimum Rate

1 pulse per 4 minutes.

Maximum Rate

1 pulse per second.

DIGITAL OUTPUTS – TRIAC (6)

12 VA at 24 Vac, 50/60 Hz, each output individually isolated.

UNIVERSAL OUTPUTS (3)

0 to 20 mA

Output load from 80 to 550 ohms.

0 to 10 V

With external 500 ohms, 1/2 W, 1% resistor.

Capable of Driving Functional Devices RIBUI1C Relay

UO configured for 0 to 20 mAdc, no external resistor.

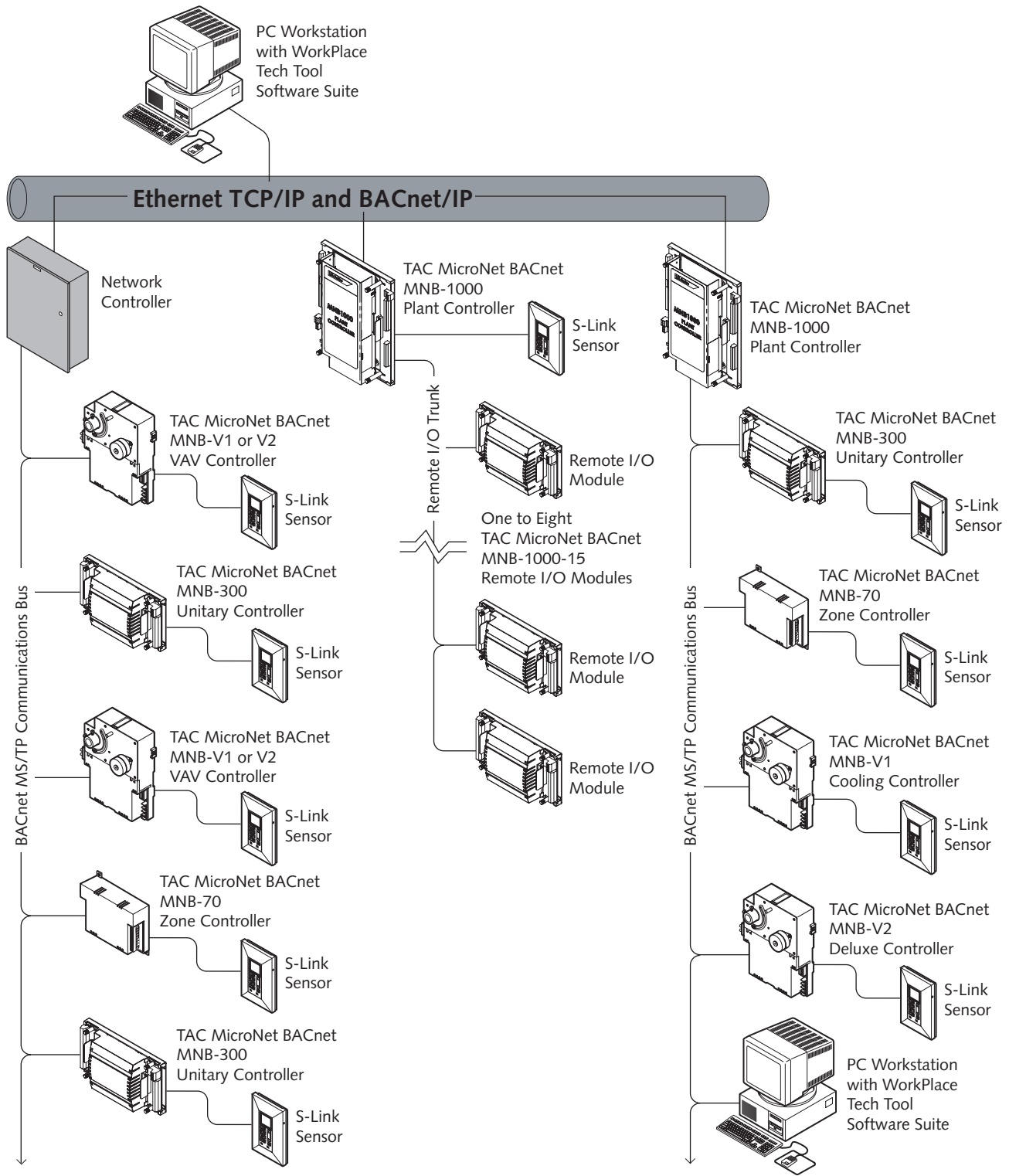

Figure-2 TAC I/A Series BACnet Topology.

© Copyright 2008, TAC

All brand names, trademarks and registered trademarks are the property of their respective owners. Information contained within this document is subject to change without notice. Distributed, manufactured, and sold by TAC. I/A Series trademarks are owned by Invensys Systems, Inc. and are used on this product under master license from Invensys. Invensys does not manufacture this product or provide any product warranty or support. For service, support, and warranty information, contact TAC at 1-888-444-1311.

F-27487
February 2008



TAC
1354 Clifford Avenue
PO Box 2940
Loves Park, IL 61132-2940

www.tac.com

